

# TORUS 2000 DUAL FUEL

Category II or Category IV Appliance  
(see Installation and Operation Manual for venting information)

## CODE OPTIONS

CSD-1	FIRMWARE W/REMOTE TEST MANUAL RESET LWCO
-------	---

## INDOOR UNIT

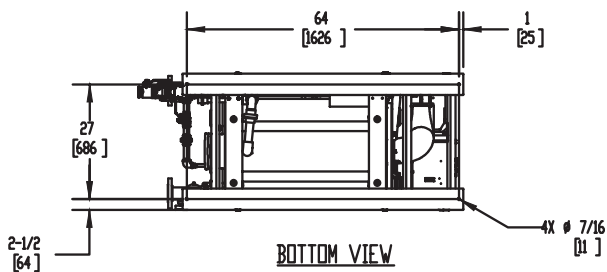
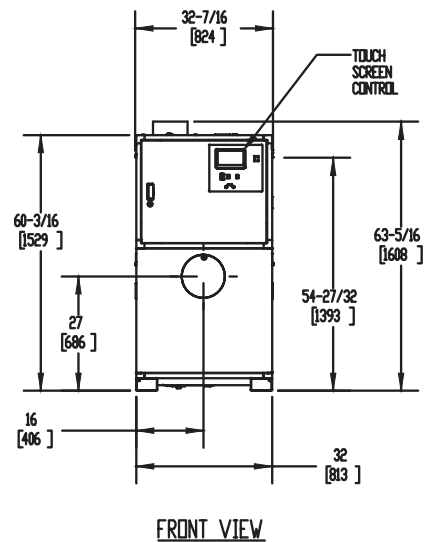
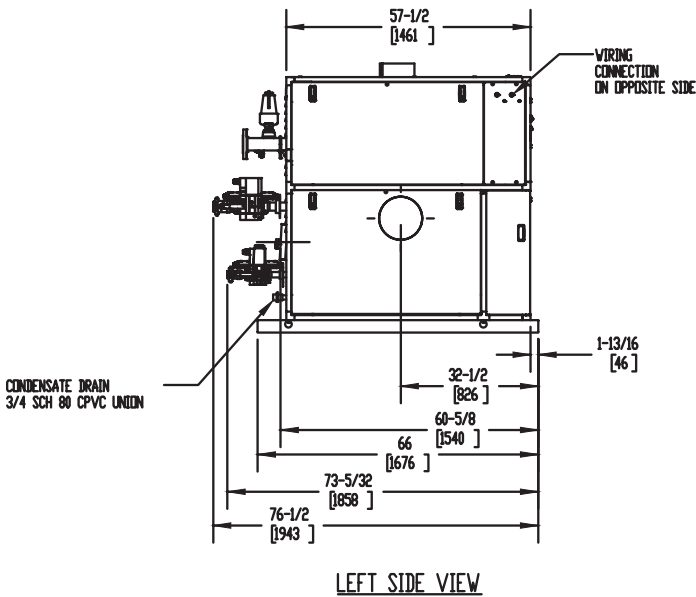
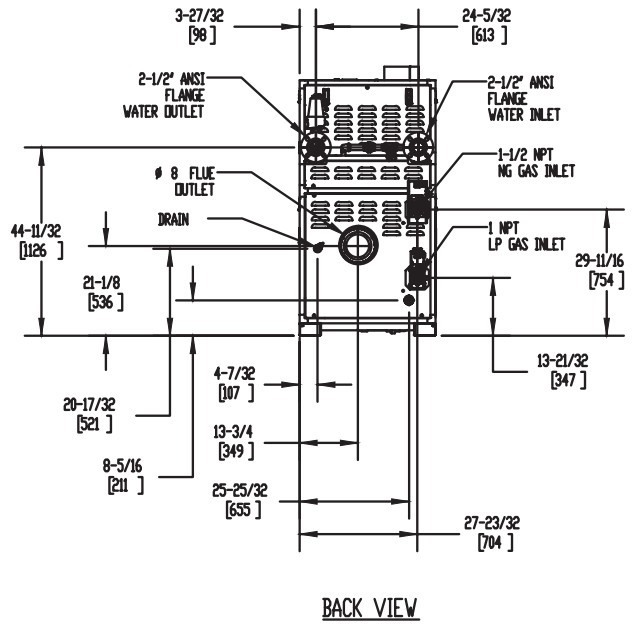
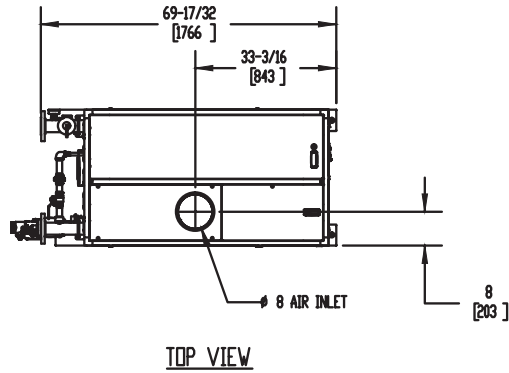

### Notes:

1. Dimensions are approximate and should not be used to "rough-in" equipment.
2. Dimensions are subject to change without notice.
3. All dimensions are in inches (mm).
4. Symbol indicates center of gravity.

## BOILER CERTIFIED RATINGS & CAPACITIES

<b>Fuel Type</b>	Natural/Propane Gas	<b>Boiler FLA</b>	25.6
<b>Input BTU/hr.</b>	1,999,000 / 586 kW	<b>Boiler HP</b>	57.66
<b>Output BTU/hr.</b>	1,929,035 / 565 kW	<b>Min. Gas Pressure Required</b>	4" W.C.
<b>Electrical Requirements</b>	230 VAC/60 Hz/1PH	<b>Max. Gas Pressure Allowed</b>	14" W.C.
		<b>Operating Weight</b>	1388 lbs / 630 kg

## BOILER TRIM & CONTROLS

<b>Main Gas Valve</b>	Dungs MBC	<b>Air Switch</b>	Huba
<b>Firing Valve</b>	1 1/2" Apollo	<b>Flow Switch</b>	SIKA
<b>Ignition Control</b>	Fenwal	<b>Blocked Flue Switch</b>	Cleveland NS2
<b>Operating Control</b>	HeatNet®	<b>Blower Motor</b>	Ametek
<b>High Limit</b>	Jumo	<b>L.W.C.O.</b>	800
<b>Main Ball Valve</b>	1 1/2" Apollo	<b>Relief Valve (WB)</b>	1" x 1-1/4" set @ 50 psi
Pump contactor strongly recommended for water heater applications.		<b>Relief Valve (WW)</b>	1" x 1" set @ 125 psi

## A.S.M.E.

<b>ASME Sect IV Fire Side Htg Surface</b>	153.19 Sq. Ft. / 14.23 Sq. M.	<b>Design Data</b>	Max. 160 psig & 210°F
<b>ASME Sect IV Water Side Htg Surface</b>	141.93 Sq. Ft. / 13.19 Sq. M.	<b>Water Volume</b>	16.9 gal. / 64 Liters

\* Add circulator amps.

## BOILER TEMPERATURE RISE / PRESSURE DROP (Based on Full Input)

20°F / 11.1°C				30°F / 16.7°C				40°F / 22.2°C				50°F / 27.8°C				60°F / 33.3°C			
Flow Rate		Pressure Drop		Flow Rate		Pressure Drop		Flow Rate		Pressure Drop		Flow Rate		Pressure Drop		Flow Rate		Pressure Drop	
GPM	L/s	Ft	kPa	GPM	L/s	Ft	kPa	GPM	L/s	Ft	kPa	GPM	L/s	Ft	kPa	GPM	L/s	Ft	kPa
193.0	12.2	20.1	60.1	128.7	8.1	9.9	29.7	96.5	6.1	6.1	18.2	77.2	4.9	4.2	12.5	64.3	4.1	3.1	9.2

## WATER HEATER HOURLY RECOVERY CAPACITY (GPH & LPH)

40°F	22°C	60°F	33°C	80°F	44°C	100°F	56°C	120°F	67°C	140°F	78°C
5819	21997	3880	14665	2910	10999	2328	8799	1940	7332	1663	6285

Flow GPM				Temp. Rise** (°F)				Vent Length (Equiv. Ft.)				Air Inlet Length (Equiv. Ft.)			
Min		Max		Min		Max		Min		Max		Min		Max	
64.3		193.0		20		60		8		160		0		160	

\*\* Min/Max delta t reflects boiler operation at full input. For applications requiring operation above/below these parameters please consult factory.

<b>REP FIRM</b>	_____	<h1 style="margin: 0;">TORUS 2000 DUAL FUEL</h1> <p style="margin: 0;"><b>Category II or Category IV Appliance</b> (see Installation and Operation Manual for venting information)</p>  <p style="margin: 0;">A Division of Mestek, Inc. Westfield, MA 01085 (413) 564-5515</p> <p style="margin: 0; font-size: small;">RELIABLE. BOLD. INNOVATIVE.</p>
<b>SUBMITTED BY</b>	_____	
<b>JOB NAME</b>	_____	
<b>ARCHITECT</b>	_____	
<b>ENGINEER</b>	_____	
<b>CONTRACTOR</b>	_____	
<b>DATE</b>	_____	

# TORUS 2000 DUAL FUEL

Category II or Category IV Appliance  
(see Installation and Operation Manual for venting information)

## CODE OPTIONS

CSD-1

FIRMWARE W/REMOTE  
TEST MANUAL RESET LWCO

## OUTDOOR UNIT

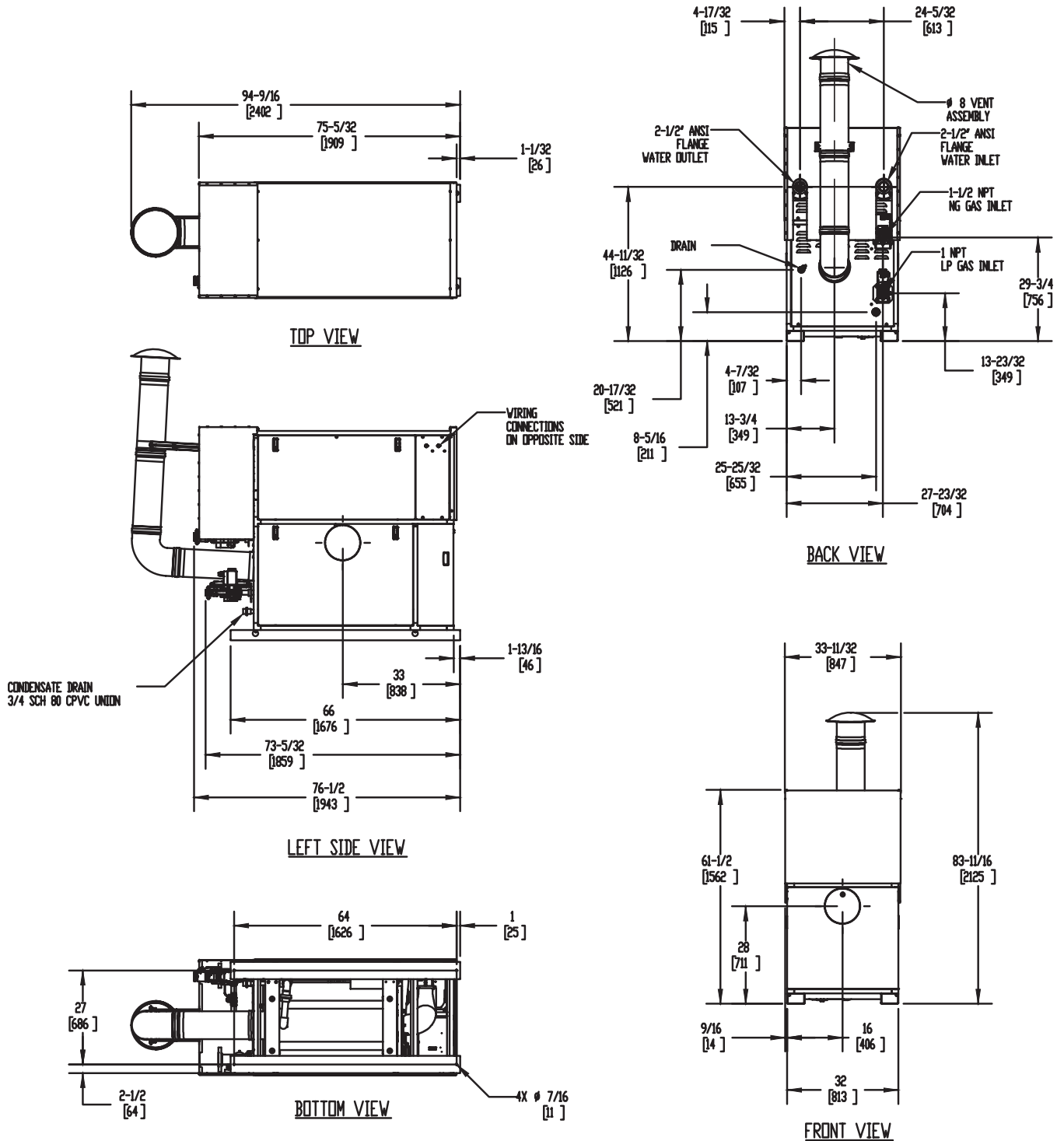

### Notes:

1. Dimensions are approximate and should not be used to "rough-in" equipment.
2. Dimensions are subject to change without notice.
3. All dimensions are in inches (mm).
4.  $\odot$  Symbol indicates center of gravity.

## BOILER CERTIFIED RATINGS & CAPACITIES

<b>Fuel Type</b>	Natural/Propane Gas	<b>Boiler FLA</b>	25.6
<b>Input BTU/hr.</b>	1,999,000 / 586 kW	<b>Boiler HP</b>	57.66
<b>Output BTU/hr.</b>	1,925,037 / 564 kW	<b>Min. Gas Pressure Required</b>	4" W.C.
<b>Electrical Requirements</b>	230 VAC/60 Hz/1PH	<b>Max. Gas Pressure Allowed</b>	14" W.C.
		<b>Operating Weight</b>	1388 lbs / 630 kg

## BOILER TRIM & CONTROLS

<b>Main Gas Valve</b>	Dungs MBC	<b>Air Switch</b>	Huba
<b>Firing Valve</b>	1 1/2" Apollo	<b>Flow Switch</b>	SIKA
<b>Ignition Control</b>	Fenwal	<b>Blocked Flue Switch</b>	Cleveland NS2
<b>Operating Control</b>	HeatNet®	<b>Blower Motor</b>	Ametek
<b>High Limit</b>	Jumo	<b>L.W.C.O.</b>	800
<b>Main Ball Valve</b>	1 1/2" Apollo	<b>Relief Valve (WB)</b>	1" x 1-1/4" set @ 50 psi
Pump contactor strongly recommended for water heater applications.		<b>Relief Valve (WW)</b>	1" x 1" set @ 125 psi

## A.S.M.E.

<b>ASME Sect IV Fire Side Htg Surface</b>	153.19 Sq. Ft. / 14.23 Sq. M.	<b>Design Data</b>	Max. 160 psig & 210°F
<b>ASME Sect IV Water Side Htg Surface</b>	141.93 Sq. Ft. / 13.19 Sq. M.	<b>Water Volume</b>	16.9 gal. / 64 Liters

\* Add circulator amps.

## BOILER TEMPERATURE RISE / PRESSURE DROP (Based on Full Input)

20°F / 11.1°C				30°F / 16.7°C				40°F / 22.2°C				50°F / 27.8°C				60°F / 33.3°C			
Flow Rate		Pressure Drop		Flow Rate		Pressure Drop		Flow Rate		Pressure Drop		Flow Rate		Pressure Drop		Flow Rate		Pressure Drop	
GPM	L/s	Ft	kPa	GPM	L/s	Ft	kPa	GPM	L/s	Ft	kPa	GPM	L/s	Ft	kPa	GPM	L/s	Ft	kPa
192.6	12.1	20.0	59.8	128.4	8.1	9.9	29.6	96.3	6.1	6.1	18.1	77.0	4.9	4.2	12.5	64.2	4.0	3.1	9.2

## WATER HEATER HOURLY RECOVERY CAPACITY (GPH & LPH)

40°F	22°C	60°F	33°C	80°F	44°C	100°F	56°C	120°F	67°C	140°F	78°C
5819	21997	3880	14665	2910	10999	2328	8799	1940	7332	1663	6285

Flow GPM				Temp. Rise** (°F)				Vent Length (Equiv. Ft.)				Air Inlet Length (Equiv. Ft.)			
Min		Max		Min		Max		Min		Max		Min		Max	
64.2		192.6		20		60		8		160		0		160	

\*\* Min/Max delta t reflects boiler operation at full input. For applications requiring operation above/below these parameters please consult factory.

<b>REP FIRM</b>	_____	<h1 style="margin: 0;">TORUS 2000 DUAL FUEL</h1> <p style="margin: 5px 0;"><b>Category II or Category IV Appliance</b> (see Installation and Operation Manual for venting information)</p>  <p style="margin: 5px 0;">A Division of Mestek, Inc. Westfield, MA 01085 (413) 564-5515</p> <p style="margin: 5px 0; font-size: small;">RELIABLE. BOLD. INNOVATIVE.</p>
<b>SUBMITTED BY</b>	_____	
<b>JOB NAME</b>	_____	
<b>ARCHITECT</b>	_____	
<b>ENGINEER</b>	_____	
<b>CONTRACTOR</b>	_____	
<b>DATE</b>	_____	